



V-ZUG-Home

Install the app, network your appliances and benefit from a wide range of useful functions.



Operating instructions

Steamer V4000

Steamer

Thank you for choosing to buy one of our products. Your appliance is made to high standards and is easy to use. Nevertheless, please take the time to read these operating instructions in order to familiarize yourself with the appliance and get the best use out of it.

Please follow the safety precautions.

Modifications

Text, diagrams and data correspond to the technical standard of the appliance at the time these operating instructions went to press. The right to make technical modifications for the purpose of the further development of the appliances is reserved.

Validity

These operating instructions apply to:

Model designation	Type	Size system
Steamer V4000 45	S4T-23026	60-450

Variations depending on the model are noted in the text.



Download updates to your appliance via V-ZUG-Home so that you are always up to date. The latest operating instructions with the new functions incorporated can be found here: vzug.com.

Contents

1	Safety precautions	5	5.2	Regeneration	27
1.1	Symbols used	5	5.3	Vacuisine	27
1.2	General safety precautions	5	5.4	Keep warm	28
1.3	Appliance-specific safety precautions	5	5.5	Wellness	28
1.4	Instructions for use	6	5.6	Hygiene	29
2	Using for the first time	9	5.7	EasyCook	29
3	Appliance description	9	6	V-ZUG-Home	31
3.1	Construction	9	6.1	Conditions	31
3.2	Operating and display elements	10	6.2	Initial set-up	31
3.3	Cooking space	11	7	User settings	32
3.4	Accessories	12	7.1	Adjusting user settings	32
4	Operation	13	7.2	Language	32
4.1	Operating the display	13	7.3	Childproof lock	32
4.2	Filling the water tank	14	7.4	Display	32
4.3	Selecting and starting an application	15	7.5	Signals and tones	32
4.4	Changing an application	16	7.6	Individual settings	33
4.5	Operating time	16	7.7	Assistance functions	34
4.6	Delayed start / end	17	7.8	Date and time	34
4.7	Options	18	7.9	V-ZUG-Home	35
4.8	Checking and changing the settings	18	7.10	Appliance information	35
4.9	Setting to start later	19	7.11	Factory settings	35
4.10	Application tips	19	7.12	EcoManagement	36
4.11	Favourites	19	7.13	Customer Services	36
4.12	Pinning	20	8	Care and maintenance	36
4.13	Timer	21	8.1	Cleaning the exterior	36
4.14	Display lock	22	8.2	Cleaning the cooking space	36
4.15	Quiet mode	22	8.3	Steam cleaning	37
4.16	Time	23	8.4	Cleaning the appliance door	37
4.17	Cancelling / ending before time	23	8.5	Cleaning the door seal	39
4.18	End of operation	24	8.6	Replacing the door seal	39
4.19	Subsequent steps	24	8.7	Cleaning the accessories and shelf guides..	39
4.20	Switching the appliance off	25	8.8	Descaling	40
4.21	Emptying the water tank	26	9	Trouble-shooting	42
4.22	Appliance tips	26	9.1	Error messages	42
5	Applications	26	9.2	Other possible problems	43
5.1	Steam	26	9.3	After a power failure	44

10	Accessories and spare parts	45
10.1	Accessories.....	45
10.2	Special accessories.....	45
10.3	Spare parts.....	45
11	Technical data	45
11.1	Note for testing institutes.....	45
11.2	Temperature measurement.....	46
11.3	Product fiche.....	46
11.4	Product information	46
11.5	EcoStandby	46
12	Tips and tricks	47
12.1	General tips.....	47
13	Disposal	47
	Index	48
14	Service & Support	51

1 Safety precautions

1.1 Symbols used



Denotes important safety precautions.

Failure to observe said precautions can result in injury or damage to the appliance or equipment!



Information and notes to be observed.



Information on disposal



Information about the operating instructions

- ▶ Indicates step-by-step instructions.
 - Describes how the appliance reacts to the steps taken.
- Indicates a list.

1.2 General safety precautions



- Read the operating instructions before using the appliance for the first time.



- This appliance can be used by children aged 8 and above and by persons with reduced physical, sensory or mental capabilities, or lack of experience and/or knowledge, provided they are supervised or have been instructed on the safe use of the appliance and have understood the hazards involved. Children shall not play with the appliance.

Cleaning and user maintenance shall not be undertaken by children without supervision.

- If an appliance is not equipped with a mains cable and a plug or other means for disconnecting from the mains with a contact opening on each pole complying with the conditions of overvoltage category III for full isolation, an isolating device must be incorporated into the permanently installed electrical installation in accordance with the installation regulations.
- If the mains cable of this appliance is damaged, it must be replaced by the manufacturer or its Customer Services or a similarly qualified person in order to avoid hazard.

1.3 Appliance-specific safety precautions



- **READ THE IMPORTANT SAFETY PRECAUTIONS CAREFULLY AND RETAIN FOR FUTURE USE.**
- **WARNING:** The appliance and its accessible parts get hot during use. Be careful not

- to touch the heating elements. Children under 8 years of age must be kept away from the appliance unless they are constantly supervised.
- **WARNING:** Accessible parts can get hot during use. Keep young children away from the appliance.
 - This appliance is intended for use in the home and similar settings such as: in staff kitchens in shops, offices and other commercial establishments; in agricultural establishments; by guests in hotels, motels and other accommodation establishments; in bed and breakfast establishments.
 - This appliance is not intended for use in vehicles or on board ships or aircraft or in rooms where there are special conditions such as, for instance, a corrosive or explosive atmosphere (dust, steam or gas) or condensing moisture.
 - Do not use aggressive or abrasive cleaning agents or sharp metal scrapers for cleaning the glass in the oven door as they could scratch the surface. This can destroy the glass.
 - Under no circumstances use a steam cleaner to clean the appliance.
 - To avoid overheating, the appliance must not be installed behind a decor door.
 - **WARNING:** Never heat food or liquids in sealed containers such as cans or bottles as they are liable to explode due to overpressure.
 - See the «Accessories» section for the proper use of insertable parts.

1.4 Instructions for use

Before using for the first time

- The appliance must be installed and connected to the electricity supply in accordance with the separate installation instructions. Have a qualified fitter/ electrician carry out the necessary work.

Correct use

- The appliance is designed for use in the home for preparing food. Under no circumstances flambé or cook food using a lot of fat in the cooking space! No liability is assumed for any damage caused by improper use or incorrect handling.
- Never use the appliance to dry animals, textiles, paper, etc.!
- Do not use the appliance as a room heater.
- The appliance should only be installed and operated at an ambient temperature of 5 °C to 35 °C. If frost develops, residual water left in the pumps could freeze and cause damage.

- Any repairs, modifications or manipulations to the appliance, especially any electrically live parts, may only be carried out by the manufacturer, its Customer Services or a similarly qualified person. Repairs if carried out incorrectly may cause serious injury, damage to the appliance and fittings, as well as affect the functioning of the appliance. If the appliance is not working properly or in case a repair is needed, follow the instructions given in the «Service & Support» section. If required, please contact our Customer Services.
- Use original spare parts only.
- Retain these operating instructions for future reference.
- The appliance corresponds to recognized technology standards and the relevant safety regulations. Proper use of the appliance is essential to avoid damage and accidents. Please therefore follow the precautions given in these operating instructions.
- Do not attach magnets to the display.
- Steam and/or hot air may escape from the cooking space when the appliance door is opened.
- The heated appliance will remain hot for some time after it is switched off and will cool down only slowly to room temperature. Allow sufficient time for the appliance to cool down before, for instance, cleaning it.
- Overheated fat and oil can easily catch fire. Heating oil in the cooking space to sear meat is dangerous and should not be done. Never attempt to extinguish burning oil or fat with water. Danger of explosion! Smother the flames with a fire blanket. Keep doors and windows closed.
- Do not pour spirits (brandy, whisky, schnapps, etc.) over hot food. Danger of explosion!
- Do not leave the appliance unattended when drying herbs, bread, mushrooms, etc. If the foodstuff dries out too much, it can pose a fire hazard.
- If you notice smoke possibly coming from a fire in the appliance or inside the cooking space, keep the appliance door closed and disconnect the appliance from the mains power supply.

Note on use

- Use the childproof locking facility.
- If the appliance is visibly damaged, do not use it. Contact our Customer Services.
- If the appliance is not functioning properly, disconnect it from the power supply immediately.
- Ensure there are no foreign bodies or pets in the cooking space before closing the appliance door.
- Objects that could pose a danger if the appliance were accidentally switched on should not be stored in the cooking space. Do not store food or any temperature-sensitive or inflammable materials, e.g. cleaning agents, oven sprays, etc., in the cooking space.

Caution: Risk of burns!

- The appliance gets very hot when in use. The appliance door also gets hot.

Caution: Risk of injury!

- Be careful not to put fingers in the door hinges, as there is otherwise a risk of injury if the appliance door is moved. Particular care should be taken when children are around.
- Only leave the appliance door open in the airing position. An open appliance door poses a danger of tripping or injury! Do not sit or rest on the appliance door or use it as a storage surface.
- For cookers: A hob guard can be fitted to protect small children. Hob guards are available from specialist retailers.

Caution: Risk to life!

- Danger of suffocation! Keep packaging material, e.g. plastic film and polystyrene, away from children. Packaging material can be dangerous for children.

How to avoid damaging the appliance

- Close the appliance door carefully.
- Do not place any protective insert or aluminium foil on the floor of the cooking space with appliances with no visible bottom heating element.
- Do not use objects that can rust in the cooking space.
- Using knives or cutting wheels on the baking tray will visibly damage the surface.
- To prevent corrosion, leave the appliance door open in the airing position until the cooking space has cooled down.
- When cleaning the appliance make sure no water gets inside it. Use a moderately damp cloth. Do not spray the outside or the inside of the appliance with water. If water gets inside the appliance, it will cause damage. See the «Care and maintenance» section.
- Empty the water tank of any water that is still in it and then fill with fresh, cold drinking water.

2 Using for the first time

Before operating the newly installed appliance for the first time, the following steps should be taken:

- ▶ Remove packaging and transport materials as well as any protective blue film from out of the cooking space.
- ▶ Remove all the accessories from out of the cooking space.
- ▶ Clean the cooking space.
- ▶ Long touch the display.
 - The appliance starts.
 - Various user settings necessary for operation appear in the display one after the other.
- ▶ Make the settings and confirm.
- ▶ Fill the water tank up to the «max.» mark with fresh, cold drinking water and slot into position in the water tank compartment.
- ▶ Start the rinsing of the water system.

If the rinsing is skipped, it must be carried out manually.

- ▶ Heat the empty cooking space to 100 °C for 5 minutes using the  «Steam» application.
 - Wait 20 minutes until the appliance cools down and the water is pumped back.
- ▶ Empty the water tank and then fill with fresh water.
- ▶ Wipe down and dry the cooking space.
- ▶ Start the initial burn-in.

If the initial burn-in step is skipped, it must be carried out manually after completing the initial set-up.

- ▶ Heat the empty cooking space (without wire shelves, baking trays, etc.) to 100 °C for about 30 minutes using the  «Steam» application.



Burning-in removes any oily residues in the cooking space. As there is likely to be some smoke and odour given off, animals (especially birds) should not be in the same room during the burn-in process. Ventilate the room well both during and after the process.



All temperatures in these operating instructions are given in degrees Celsius (°C).

3 Appliance description

3.1 Construction

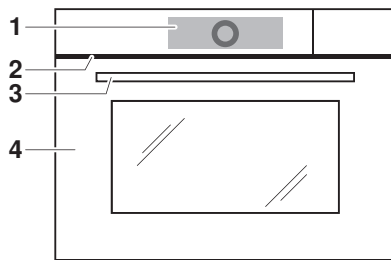

- 1 Operating and display elements
- 2 Ventilation opening
- 3 Door handle
- 4 Appliance door

3.2 Operating and display elements

App view

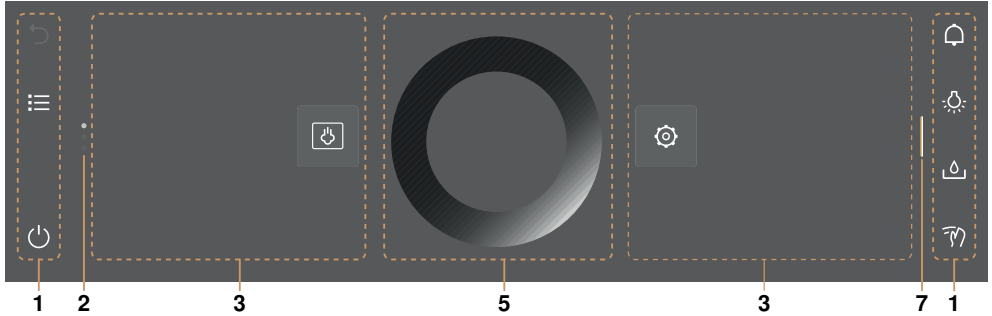

List view



- | | | | |
|---|-------------------------------------|---|------------------------------------|
| 1 | Function bars with function buttons | 5 | CircleSlider |
| 2 | Scroll bar/position | 6 | Information |
| 3 | Apps | 7 | Bar for expanding the function bar |
| 4 | List of applications | | |

Left function buttons

- | | |
|--|--------------|
| | Step back |
| | Start screen |
| | List view |
| | App view |
| | Switch off |

Right function buttons

- | | |
|--|-----------------------------|
| | Timer |
| | Open water compartment flap |
| | Display lock |
| | Quiet mode |
| | Clock |

Ready to start

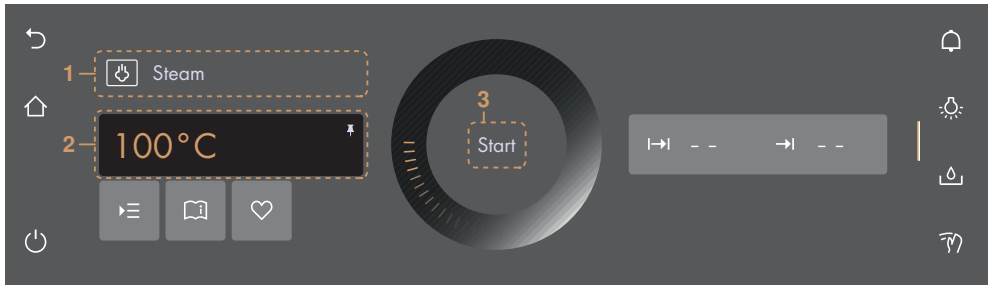

- | | | | |
|---|-------------|---|-----------------|
| 1 | Application | 3 | Start operation |
| 2 | Main value | | |

Setting options

- | | | | |
|---|------------------|-----|----------------|
| ☰ | Options | I→I | Operating time |
| 📖 | Application tips | →I | End |
| ♡ | Favourite | | |

Symbol



📶 V-ZUG-Home

3.3 Cooking space

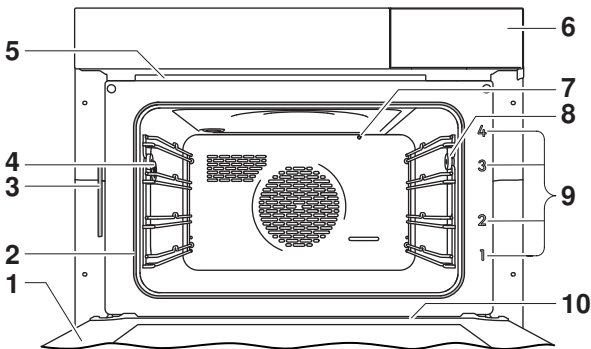

- | | | | |
|---|---------------------------|----|--------------------------------|
| 1 | Appliance door | 6 | Water tank compartment |
| 2 | Door seal | 7 | Temperature sensor |
| 3 | Identification plate | 8 | Knurled nut |
| 4 | Climate sensor | 9 | Levels |
| 5 | Cooking space ventilation | 10 | Door-mounted condensate trough |

3.4 Accessories



Incorrect handling can cause damage!

Do not use knives or cutting wheels on the accessories.



Do not store the accessories in the cooking space. Remove all non-ovenproof accessories before use.

Stainless steel tray

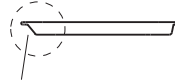
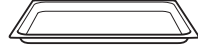

- Use together with the wire shelf or perforated cooking tray as a drip tray.
- ▶ Ensure that the «sloped» side **1** of the stainless steel tray is to the back of the cooking space.
- ▶ Only use the normal way round – not upside down.

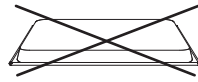

1



Perforated cooking tray

- Particularly suitable for  «Steam» and  «Vacuisine».
- For cooking fresh or frozen vegetables, meat and fish on.
- For extracting juice from berries, fruit, etc.
- ▶ Ensure that the «sloped» side **1** of the cooking tray is to the back of the cooking space.
- ▶ Only use the normal way round – not upside down.

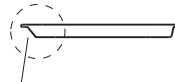
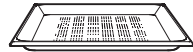

1

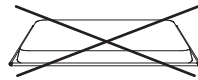

Wire shelf



If you are using your steamer in combination with an oven: Do not use the wire shelf from the oven in the steamer! Risk of rusting!

The wire shelf from the steamer is distinguished through a metal plate with a steam symbol.

- For standing roasting and baking tins on
- For standing meat, frozen pizza, etc. on
- ▶ Ensure that the bar **1** is to the back of the cooking space. This enables the food to be removed safely from the cooking space.
- Serves as a cooling rack.

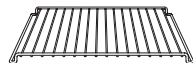
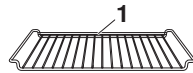

Water tank with lid



Do not use filtered (demineralized) or distilled water. Pour away any water that is left in the water tank and fill with fresh drinking water.

- ▶ Only fill with fresh, cold drinking water up to the «max.» mark.
 - The «max.» mark is in the round opening in the lid.
 - Let into it is a tab embossed with «max.».

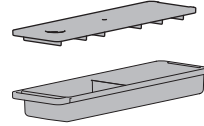

Special accessories



Place any accessories not included in the scope of delivery on the perforated cooking tray.

- ▶ Special accessories can be found at: www.vzug.com

4 Operation

4.1 Operating the display

Switching the appliance on

The appliance is operated using the display.

The clock is only visible in EcoStandby if enabled in the user settings.

- ▶ Long touch the display.
 - The start screen appears.



Changing the start screen view

The start screen can be displayed in one of two ways: as an app view (see page 10) or as a list view. The app view is the factory setting.



- ▶ To temporarily change the view, touch the **1** function button.
 - The view is retained only until the display goes dark.
 - The change is then discarded.
 - When the display is called up again, the view set in the user settings appears.
- ▶ To permanently change the view, go in the user settings to «Individual settings» and select the desired start screen view (see page 33).

Displaying quick information

The app view displays the names of the apps as well as the two favourite functions  «Rename» and  «Remove».

- ▶ Press and hold the desired app **2**.
 - Quick information and the favourites function in Favourites appear above the app (see page 19).

- ▶ Release app **2**.
 - Quick information disappears. In the Favourites  application, Quick information does not disappear in order that Rename or Remove can be selected.

Moving an app

The apps can be moved and reordered in the app view.

- ▶ Press and hold the desired app **2** and move it to change the app order.
 - The apps are spread over several pages; only one app can be moved at a time.
- ▶ Release app **2**.
 - The new app order is saved.

Expanding the right function bar

The right function bar can be expanded at any time.

- ▶ Drag the bar **3** to the left.
 - The function bar expands.
 - More functions appear in the display.

Using the CircleSlider

- ▶ Touch the desired application or function.
 - The colour of the selected range turns amber and can now be changed.
 - The temperature range is already activated and can be changed directly.
- ▶ Place your finger on the CircleSlider **4** and move it in a circle.
 - The value range changes.
- ▶ Release the CircleSlider **4**.
- ▶ Press «Start» to start an application or a function.



4.2 Filling the water tank



Do not use filtered (demineralized) or distilled water. Pour away any water that is left in the water tank and fill with fresh drinking water.

- ▶ Touch the  «Water compartment flap» function button.
 - The flap of the water tank compartment opens.
- ▶ Take the water tank out of the appliance.
- ▶ Fill the water tank with water up to the «max.» mark.
 - Only fill with fresh, cold drinking water.
 - The «max.» mark is in the round opening in the lid. Let into it is a tab embossed with «max.».
- ▶ Slot the filled water tank into position in the water tank compartment.
- ▶ Close the water compartment flap manually.

Refilling the water tank

The contents of the water tank normally suffice for one cooking session.

If, however, the water tank needs to be refilled:

- ▶ Do not pour more than 1 l of water into the water tank as otherwise water could spill over at the end of operation.

4.3 Selecting and starting an application

- ▶ Long touch the display.
 - The start screen appears.

Selecting an application group

Either:

- ▶ In the  app view, touch the desired application group.
 - The submenu with the associated applications appears in the display.

Or:

- ▶ In the  list view, select the desired application group using the CircleSlider or by swiping up or down.
- ▶ Press «OK» or touch the application.
 - The submenu with the associated applications appears in the display.

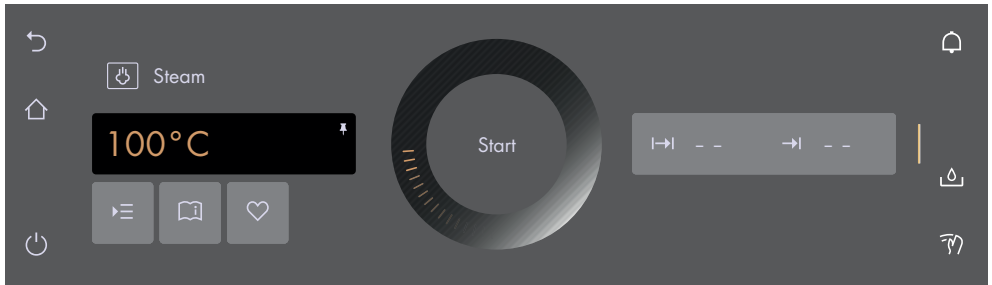

Selecting an application

- ▶ Select the desired application using the CircleSlider.
 - Choose an item in the list by swiping, navigating and touching it.
- ▶ Touch the desired application and press «OK» or touch the application again.
 - The ready to start screen or another submenu with more applications appears in the display.
- ▶ If required, repeat the procedure and select the desired application until the ready to start screen appears in the display:

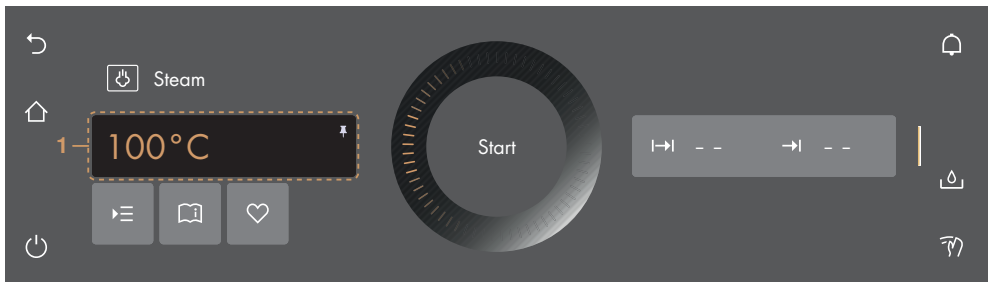

Adjusting values

- ▶ If necessary, adjust the main value **1** using the CircleSlider (see page 18).
- ▶ If necessary, touch  and define, adjust or activate the values of other options (see page 18).

Saving values

- ▶ Permanently save and pin the adjusted main value **1** for the selected application, if required (see page 20).
- ▶ Touch  and create a favourite, if required (see page 19).

Starting an application

- ▶ Press «Start» to start the application.
 - The pulsing circle **2** of the CircleSlider indicates that operation has started.
 - The progress bar **3** in the CircleSlider shows the countdown to the time remaining or the preheating status of the set application, if set.

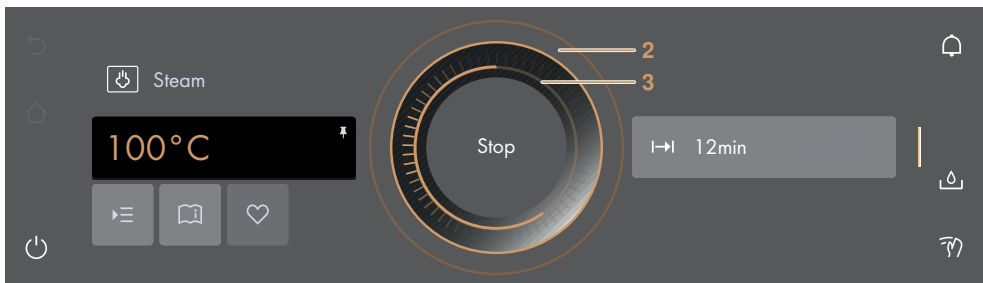

4.4 Changing an application

If an application has not started yet:

- ▶ Touch the  «Start screen» function button.
 - The start screen appears (see page 15).
 - A new application can be selected.

If an application is already running:

- ▶ Press and hold «Stop».
- The application is cancelled (see page 23).

4.5 Operating time

The operating time can be set, adjusted or cancelled before or during operation. The application ends automatically when the set duration is up.

Setting the operating time

- ▶ Select the desired application (see page 15).
- ▶ In the value range, touch  «Operating time (see page 18)».
- The colour of the value range changes to amber.
- ▶ Set the desired operating time using the CircleSlider.

- The desired duration and the calculated end time  appear in the display:

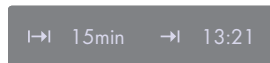

- ▶ Press «Start» to start the application.
 - The application starts and the time remaining is displayed.
 - The application ends automatically when the set duration is up (see page 24).
 - If subsequent steps are available for an application, these can be selected when the set duration is up.

Setting range

Application/function	Minimum	Maximum
Applications with steam	10 s	10 h
Vacuisine	10 s	72 h
Keep warm	5 min	1 h 30 min
Wellness	5–15 min	15 min–1 h



The operating time cannot be changed for applications with a fixed duration.

Showing the clock during operation

The clock and operating time can be shown during operation.

- ▶ Expand the function bar.
- ▶ Touch the ⌚ «Clock» function button.
 - The clock and operating time are shown in the display.

Hiding the clock during operation

- ▶ Either touch ✕ or press «OK».
 - The clock and operating time are hidden in the display.

4.6 Delayed start / end

The delayed start is activated when for the application selected both the operating time and end are set. The appliance switches automatically on and off again at the desired times.

Setting a delayed start

- ▶ Select the desired application (see page 15).
 - ▶ Set the operating time (see page 16).
 - ▶ Set further options, if required (see page 18).
 - ▶ Place the food in the cooking space.
- Before setting the delayed start,
- ▶ in the value range, touch → «End».
 - The colour of the value range changes to amber.
 - ▶ Set the desired end time using the CircleSlider.
 - The desired duration and the set end time appear in the display:

→ 15min → 13:21

- ▶ Press «Start» to start the delayed start.
 - The time set or remaining to the start of operation and the end of operation appear in the display:

Appliance starts in: 32min

→ 15min

- ▶ If necessary, check and change the settings (see page 18).
 - Any changes to the «Operating time» or «End» options cause the time remaining to the start of operation to be recalculated.



If «Operating time» has been set, the end time cannot be set or adjusted during operation.

Example

- ▶ Select the  «Steam» application and 100 °C.
- ▶ At 8:00, set an operating time of 1 hour and 15 minutes.
- ▶ Set the end time to 11:30.
 - The appliance switches on automatically at 10:15 and off again at 11:30.

4.7 Options

Overview

Each application offers different options. Your appliance has the following  «Options»:

 Start later (see page 19)

Selecting and starting options

- ▶ Select an application from the desired application group and confirm with «OK», if required (see page 15).
 - The ready to start screen appears in the display.
- ▶ Touch .
 - The options menu appears in the display:

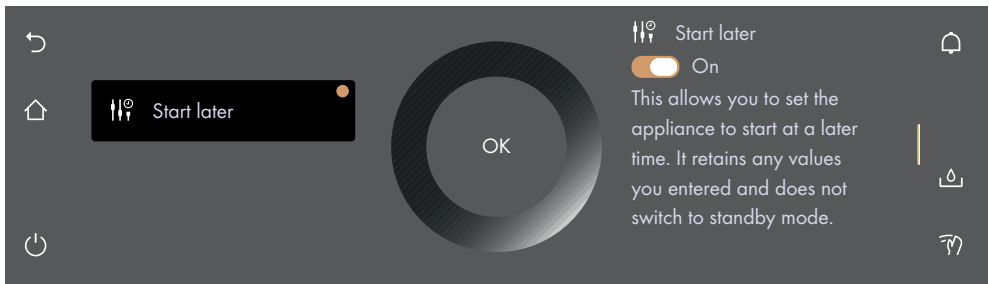

- ▶ Touch the desired option.
- ▶ In the right content pane of the display, either turn on the option with the switch or touch the value range and set the desired value using the CircleSlider.
 - Each defined option is marked with a .
- ▶ Confirm the setting with «OK».
 - Several settings can also be confirmed at once with «OK».
 - The ready to start screen appears in the display.
- ▶ Press «Start» to start the application.

4.8 Checking and changing the settings



Values and settings can be changed before and during operation. An exception is setting the end time  during operation (see page 24).

- ▶ Touch the field for the desired setting.
- ▶ To adjust or reset a value, touch the value range and adjust the value using the CircleSlider.
 - The colour of the value range changes to amber.
- ▶ To turn the option on or off, touch the switch.
- ▶ Confirm the setting with «OK».

4.9 Setting to start later

With «Start later», an application and its settings can be predefined and set to start at a later time. The application does not start automatically, but instead only through the interaction of the user. The appliance remains ready to start and does not switch to standby, resulting in higher energy consumption.

Setting «Start later»

- ▶ Select the desired application (see page 15).
- ▶ Touch  «Options» and select  «Start later».
- ▶ Touch the «Start later» switch.
 - «Start later» is turned on.
 - The settings are saved for up to 36 hours.
- ▶ Set further options, if required (see page 18).
- ▶ Place the food in the cooking space.

Starting «Start later»

- ▶ Press «Start» to start the application.
 - The application starts and the time remaining is displayed.



If both «End» and «Start later» have been set, the end time set is disregarded when starting «Start later».

4.10 Application tips

The application tips provide helpful suggestions that range from the use of suitable accessories or cookware to tips specific to a particular application.

If the application is not yet running:

- ▶ Select the desired application (see page 15).
 - The ready to start screen appears in the display.

Showing application tips

- ▶ Touch  «Application tips».
 - Tips on the particular applications are shown.



Hiding application tips

- ▶ To hide tips, touch .
 - The ready to start screen or the running operation appears in the display.

4.11 Favourites

Creating a favourite

Favourites can be created from all applications, with the exception of the cleaning programmes. And all options, with the exception of  «End», can be saved. Up to 50 favourites in total can be created.

- ▶ Select the desired application and adjust the values and settings (see page 15).
- ▶ Touch  «Favourites».
 - The favourite names menu appears in the display together with the keyboard.
- ▶ Customize the favourite name using the keyboard, if required.
- ▶ To discard favourites, touch .
- ▶ To save favourites, press «OK».
 - Quick information for the favourite is displayed.
 - The favourite **1** appears in the start screen as an app with a heart.





Changing favourites

Once a favourite has been created, it can no longer be changed.

- ▶ To adjust individual values or settings compared to the old favourite, create a new favourite and delete the old one if necessary.





Changing favourite names

The favourite name can only be changed in the app view.

- ▶ If required, touch 
 - The start screen appears as an app view.
- ▶ Press and hold the favourite **1**.
 - Quick information appears above the app.
- ▶ Touch  «Rename».
 - The favourite names menu appears in the display together with the keyboard.
- ▶ Change the favourite name using the keyboard.
- ▶ Touch  to keep the old favourite name.
- ▶ Press «OK» to save the new favourite name.

Deleting favourites

The favourite can only be deleted in the app view.

- ▶ If required, touch 
 - The start screen appears as an app view.
- ▶ Press and hold the favourite **1**.
 - Quick information appears above the app.
- ▶ Touch  «Clear».
 - The following appears in the display: «Do you really want to clear or reset?»
- ▶ To keep favourites, touch  «No».
- ▶ To delete favourites, touch  «Yes».

Starting favourites

- ▶ In the start screen, touch favourite **1**.
 - The ready to start screen appears in the display.
- ▶ Press «Start» to start favourite **1**.

4.12 Pinning

To permanently change the recommended main value for an application, it can be fixed with a pin . A single main value is assigned to each application. Main values can be:

- Temperature
- Food entry



Hygiene applications and descaling cannot be pinned.

Pinning a main value

- ▶ Select the desired application (see page 15).
 - The ready to start screen appears in the display.
- ▶ Adjust the main value using the CircleSlider (see page 18).
- ▶ Press and hold the main value.
 - The colour of the pin changes to amber.
 - The main value for the desired application is fixed.
 - Whenever the application is called up, the pinned main value appears as a recommended value.

Resetting a pinned main value

- ▶ In the start screen, touch an application with a pinned main value.
 - The ready to start screen appears in the display.
- ▶ Press and hold the amber-coloured main value.
 - The colour of the pin changes to white.
 - The main value for the desired application is no longer fixed.
 - Whenever the application is called up, the recommended default value appears.



To reset all pinned main values, go to the user setting «Pinned values» (see page 35).

4.13 Timer

The timer functions like an egg timer. It can be used independently of other functions and applications.

Setting and starting the timer

- ▶ Touch the  «Timer» function button in the right function bar.
 - The timer is shown in the display.
 - The recommended value 1 appears in amber.
- ▶ Set the desired operating time using the CircleSlider.

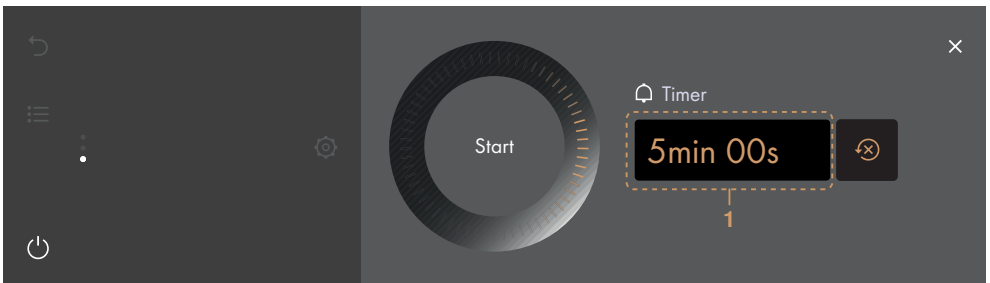

- ▶ Press «Start».
 - The start screen appears.
 - The countdown to the time remaining appears in the function bar.

When the duration is up

- an acoustic signal is emitted.
- «Timer finished» appears in the display.
- ▶ Press «OK» to confirm the message.

Checking and changing

- ▶ Touch the  «Timer» function button.
 - The countdown to the time remaining appears in the display.

- ▶ Press and hold «Stop».
 - The timer is interrupted.
- ▶ Shorten or extend the duration of the timer using the CircleSlider.
- ▶ Press «OK» to confirm the shortening or extending of the duration of the timer.
 - The change to the duration of the timer is saved.
 - The start screen appears.
 - The countdown to the time remaining appears in the display.



The next time the timer is called up, the last duration set automatically appears as the recommended value.



Turning the timer off before time

- ▶ Touch the  «Timer» function button.
 - The countdown to the time remaining appears in the display.
- ▶ Press and hold «Stop».

4.14 Display lock

This function locks the display to, for example, enable the display to be cleaned or prevent accidental changes to the values. The appliance continues to operate and messages are still displayed.

Turning on the display lock

- ▶ Touch the  «Display lock» function button.
 - The following appears in the display: «Activate»
- ▶ Touch «Activate».
 -  appears in the display.



Turning off the display lock

- ▶ Press and hold .
 - The display is unlocked.



4.15 Quiet mode

The appliance runs as quietly as possible when in quiet mode. All tones are set at the lowest volume. The quiet mode can be turned on and off in the user settings (see page 32) as well as by using the quick access in the function bar.

Turning on the quiet mode

- ▶ Expand the function bar.
- ▶ Touch the  «Quiet mode» function button.
 - The quiet mode is shown in the display.
- ▶ Touch the «Quiet mode» switch.
 - «Quiet mode» is turned on.
 - The colour of the  «Quiet mode» changes to amber in the function bars.

Turning off the quiet mode

- ▶ Expand the function bar.
- ▶ Touch the  «Quiet mode» function button.
 - The quiet mode is shown in the display.
- ▶ Touch the «Quiet mode» switch.
 - «Quiet mode» is turned off.
 - The colour of the  «Quiet mode» changes to white in the function bars.

4.16 Time

The clock can be shown at any time.

Showing the clock

- ▶ Expand the function bar.
- ▶ Touch the ⌚ «Clock» function button.
 - The clock is shown in the display.
 - If set, the operating time of an application is also shown.

Hiding the clock

- ▶ To hide the clock, touch ✕.
 - The clock is hidden in the display.

4.17 Cancelling / ending before time

Applications that are running can be cancelled or ended before time.

Cancelling an application

- ▶ Press and hold «Stop».

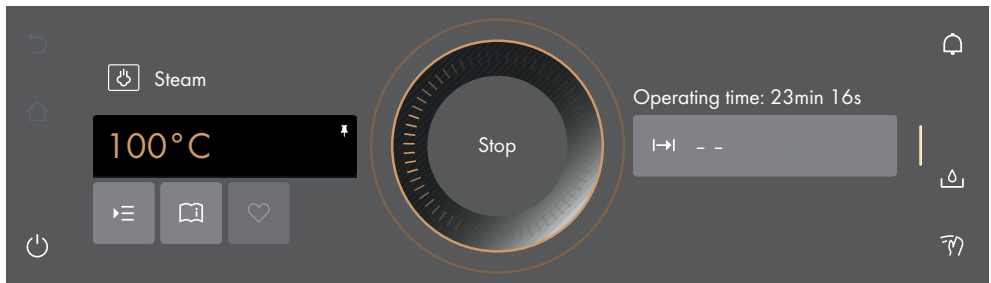

- The application is cancelled.
- A feedback tone is emitted, if enabled.
- Depending on the application, the following available options are displayed:
 - Confirm the question «Do you really want to end the application?» with ✓ «Yes».
 - Select one of the subsequent steps displayed to continue operation.
 - Select the ↶ function button to access the parent application menu.
 - Select the 🏠 function button to access the start screen (see page 15).
 - Press and hold the ⏻ function button to switch the appliance off (see page 25).



If the application has been running for less than 1 minute when cancelled, the ready to start screen appears.

Ending an application before time

- ▶ Press and hold the ⏻ function button.
 - Any running application is ended; if turned on, the timer will remain active.
 - If turned on, the display lock is deactivated.
 - The appliance switches off (see page 25).

4.18 End of operation

When the set duration / the step duration is up.

- The application ends automatically.
- An acoustic signal is emitted.
- If subsequent steps are available, the following appears in the display: «The operation has finished. Do you want to proceed with a subsequent step?»
- ▶ Press «No» to end operation now.
- ▶ Press «Yes» to confirm the message.
 - Depending on the application, the following available options are displayed:
 - Select one of the subsequent steps displayed to continue operation.
 - Select the ↶ function button to access the parent application menu.
 - Select the ↵ function button to access the start screen (see page 15).
 - Press and hold the ⏻ function button to switch the appliance off (see page 25).

In EcoStandby as long as the temperature in the cooking space is over 80° C.

- In the display appears: «Residual heat in the cooking space». The actual cooking space temperature is also displayed.



Food can be kept warm with residual heat for some time.

After 3 minutes without interaction.

- The display goes dark and the appliance switches off automatically (see page 25).

Removing the cooked food from the cooking space



Risk of burns!

Hot steam may escape from the cooking space when the appliance door is opened. The accessories get hot. Use protective gloves or oven cloths.

- ▶ Take the food out of the cooking space when done.
- ▶ Any condensate or food particles in the cooking space must be completely removed after each cooking session with steam.
- ▶ Wipe away traces of water or soiling with a soft cloth to prevent corrosion and unpleasant odours.
- ▶ Leave the appliance door open in the airing position until the cooking space has cooled down and dried out.

4.19 Subsequent steps

Subsequent steps are applications that can be used to continue operation after an application has ended or been cancelled. Operation can be extended for the application that has just ended. The selection of subsequent steps available depends on the application that has just ended or been cancelled.

When an application ends or is cancelled and the message «The operation has finished. Do you want to proceed with a subsequent step?» is confirmed with «Yes» (see page 24),

- the subsequent step available for selection appears in the display:





Continuing operation

- ▶ Select the desired subsequent step.
 - With subsequent step **1**, the application just ended or cancelled is resumed. The main value (temperature or temperature setting) is taken over directly from the application that has ended or been cancelled.
- ▶ Confirm the selection with «OK».
 - The ready to start screen with reduced setting options appears in the display.
- ▶ If required, touch  and set the options (see page 18).
- ▶ Press «Start» to start the subsequent step.

Cancelling operation

To cancel operation, the following options are available:

- Select the  function button to access the start screen (see page 15).
- Press and hold the  function button to switch the appliance off (see page 25).

After 3 minutes without interaction.

- The display goes dark and the appliance switches off automatically (see page 25).

4.20 Switching the appliance off

- ▶ Press and hold the  function button.
 - Any running application is ended; if turned on, the timer will remain active.
 - If turned on, the display lock is deactivated.
 - For applications with steam, the steam is eliminated.
 - The display goes dark.
 - The appliance is in EcoStandby.

Display after switching off

Depending on the application and settings, the following is shown in the darkened display.

- The residual heat and the temperature if it is above 80 °C.
- «Do not remove the water tank» after all applications with steam, as long as the water system has not been emptied.

4.21 Emptying the water tank



Risk of scalding!

The water in the tank may be hot. If the following appears in the display: «Do not remove the water tank», the temperature of the residual water is too high and cannot be pumped back yet. Do not remove the water tank!

For safety reasons, the residual water is only pumped off when it reaches below a certain temperature.

After switching off the appliance

- the residual water in the boiler is pumped back into the water tank.
- in the display appears: «The water is being pumped off».

Once the water has been pumped off,

- ▶ Touch the  «Open water compartment flap» function button.
 - The flap of the water tank compartment opens.
- ▶ Remove, empty and dry the water tank.
- ▶ Slot the water tank back into position in the water tank compartment.
- ▶ Close the water compartment flap manually.



Any application can be started again.

4.22 Appliance tips

Appliance tips provides tips on operating the appliance by topic.

Topics

The following topics can be called up:

- Start screen
- Function bars
- CircleSlider
- App view
- List view
- Favourites
- Pinning
- EasyCook
- Cleaning

Calling up appliance tips

- ▶ In the start screen, touch  «Appliance tips».
 - The appliance tips menu appears in the display.
- ▶ Select the desired topic.
 - Information on the desired topic appears in the right content pane of the display.

5 Applications

5.1 Steam



Temperature range	30–100 °C
Recommended value	100 °C
Level	1 to 4

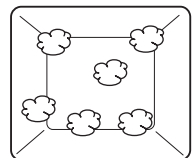

The cooking space is heated by steam. The food is heated up or cooked by steaming.

Uses

- Steaming vegetables, rice, cereal products, pulses and egg dishes
- Poaching meat, poultry and fish
- Extracting juice from fruit and berries
- Making yogurt
- Preserving, bottling



Possible to steam on several levels simultaneously.

- ▶ Put the stainless steel tray under the perforated cooking tray to make cleaning the cooking space easier.

5.2 Regeneration



Temperature range	80–150 °C
Recommended value	120 °C
Level	1 to 4

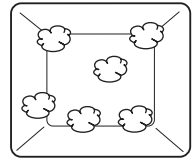

The cooking space is heated by steam and hot air. The food is reheated gently without drying it out.

Uses

- Reheating pre-cooked foods and convenience foods



Possible to regenerate on several levels simultaneously.



For crispier results (e.g. to crisp up bread and flans), set a higher temperature (150 °C).

5.3 Vacuisine

With  «Vacuisine», meat, fish, vegetables and fruit can be prepared sous vide. The vacuum-packed food is gently steamed. The desired (food probe) temperature for the food can be set using the cooking space temperature. This ensures that the food is cooked to the same degree of doneness throughout.



Temperature range	30–95 °C
Recommended value	60 °C
Level	1 to 4
Recommended maximum cooking time	72 hours

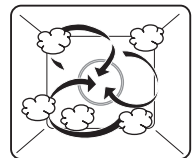

The cooking space is heated simultaneously by steam and hot air. The food is heated or cooked by steam.

Tips for best results

- Only use fresh food. This applies to meat and fish in particular. Food that has already been kept for some time has a higher bacterial content and is therefore unsuitable for Vacuisine.

- Meat quality: both lean (e.g. fillet) and marbled, more sinewy (e.g. stewing meat and belly pork) cuts of meat can be prepared optimally using Vacuisine.

Preparing the food

- Vacuum seal the food. For this, see the tips in the operating instructions for the vacuum drawer, on the homepage or in the recipe brochure.

Selecting and starting Vacuisine

- ▶ Put the perforated cooking tray into the cooking space and place the vacuum-sealed food in it.





Ensure that the bags are adjacent and not overlapping so that the steam can circulate and cook the food evenly.



The filled water tank must be in position in the water tank compartment. For long cooking times, the water tank may need to be refilled. A corresponding message will appear.



If the desired cooking time is longer than 10 hours, place the stainless steel tray underneath the perforated cooking tray.

- ▶ Long touch the display.
 - The start screen appears.
- ▶ Select the  «Vacuisine» application and confirm with «OK», if required (see page 15).
 - The settings for Vacuisine appear in the display.
- ▶ Make any desired settings (see page 18).
- ▶ Press «Start» to start  «Vacuisine».

5.4 Keep warm

Cooked foods can be kept warm using  «Keep warm».



If the cooking space is already hot, open the appliance door and allow the cooking space to cool down for about 10 minutes before starting the «Keep warm» function. This ensures that the food does not overcook. The longer the food is kept warm, the greater the changes may be to the consistency of the food.

5.5 Wellness

With  «Wellness», the following objects can be prepared for personal well-being:



Refreshing towels



Hot massage stones



Hot wraps



Seed cushions



Caution hot!

Feel the temperature of the heated objects with your hand first before placing them on any other parts of the body.

Refreshing towels

Before starting the application:

- ▶ Wet and wring out the towels.
- ▶ Open the towels and place in the perforated cooking tray or:
- ▶ Roll up the towels to the desired size and place in the perforated cooking tray.

Hot wraps

Before starting the application:

- ▶ Spread the prepared towels out across the perforated cooking tray.

Hot massage stones

Before starting the application:

- ▶ Put the clean, smooth massage stones in a suitable container and place it directly on the floor of the cooking space.

Seed cushions

Before starting the application:

- ▶ Place the cherry stone or grape seed cushions in the perforated cooking tray.

5.6 Hygiene

 «Hygiene» can be used for sanitizing containers. The following applications are available:

- | | | | |
|---|-------------------------|---|--------------|
|  | Hygiene baby bottles |  | Preserve jam |
|  | Hygiene preserving jars | | |

Hygiene baby bottles

This application replaces the need to boil feeding bottles in water.

Before starting the application:

- ▶ Clean the bottles.
- ▶ Unscrew the bottles and place all parts into the perforated cooking tray.

After the application has finished:

- ▶ Stand the bottles upside down on a clean kitchen towel and allow to dry thoroughly.

Hygiene preserving jars

This application replaces the need to prepare empty jars by rinsing them with hot water.

Preserve jam

This application helps to preserve the jam for longer.

5.7 EasyCook

 EasyCook helps you to prepare any food simply and conveniently. After choosing the food group and food, the appliance suggests suitable applications, including settings and accessories.

 The brochure of the same name, which you received with the operating instructions, contains the same settings information in paper form.

The values given for temperature and duration serve only as guide. They may vary depending on the type and size of the food as well as on individual preference.

Overview of food groups

Foodstuffs are grouped into different categories; a foodstuff may be included in more than one group.

The following food groups can be selected:

- | | |
|------------------|-------------------|
| Accompaniments | Fruit and berries |
| Desserts | Poultry |
| Eggs | Vegetables |
| Fish and seafood | Dairy products |
| Meat | |

Selecting and starting foods



A delayed start is only suitable for food that does not need to be refrigerated or to rise.

- ▶ Long touch the display.
 - The start screen appears.
- ▶ Select the 🍴 «EasyCook» application and confirm with «OK», if required (see page 15).
- ▶ Select the desired food group.
- ▶ Select the desired type of food.
- ▶ Select the shape (whole, in pieces, etc.) of the food and confirm with «OK», if required.
- ▶ Select the preparation method (cooking, baking, etc.) and confirm with «OK», if required.
 - The settings for the chosen food appear in the display.
- Make any desired settings (see page 18).
- Press «Start» to start operation.

Dietary styles

In the user settings in the section «Individual settings» under «EasyCook – dietary style», certain foods and/or food groups can be deactivated so that EasyCook can be adapted to suit a personal dietary style.

The following foods are available:

Milk	Meat
Eggs	Pork
Fish	

All activated foodstuffs are highlighted in amber. They can be deactivated by touching the switch.

Only where this is clear, are foods excluded. For example, if «Milk» is excluded, only foods and dishes that clearly contain «Cow's milk» will be hidden. Any number of dietary styles can be excluded.

Cuisines from around the world

In the user settings in the section «Individual settings» under «EasyCook – cuisines from around the world», country- and region-specific foods and basic dishes along with their preparation methods can be activated as a package.

The following national cuisines are available:

- Italian
- French
- German
- Lebanese
- Chinese
- Australian
- Ukrainian
- Turkish
- Belgian
- Russian

All activated national cuisines are highlighted in amber. They can be deactivated by touching the switch.

The activated foods and basic recipes in each packet are then integrated into the structure of the EasyCook menu. Any number of national cuisines can be activated.

6 V-ZUG-Home



Download updates to your appliance via V-ZUG-Home so that you are always up to date.

Hereby, V-ZUG Ltd declares that the radio equipment type is in compliance with Directive 2014/53/EU. The full text of the EU declaration of conformity is available at the following internet address: <https://www.vzug.com/gb/en/guidance-for-testing-institutes>

6.1 Conditions

The following conditions must be met for full use of V-ZUG-Home:

- Access to the internet and to Google Play™ Store / App Store®
- Smartphone or tablet that is connected to the home network
- WLAN/Wi-Fi that meets one of the following standards: 2.4GHz 802.11 b/g/n



Google Play™ is a trademark of Google Inc.



Apple and the Apple logo are trademarks of Apple Inc., registered in the U.S. and other countries. App Store® is a service mark of Apple Inc.

6.2 Initial set-up



When establishing a connection, stay close to your household appliance and have the password for your wireless network at the ready.

Installing the app

- ▶ Enable bluetooth and location determination on the smartphone or tablet.
- ▶ Search the Google Play™ Store or the App Store® for «V-ZUG».
- ▶ Install and open the V-ZUG App.

Enabling the V-ZUG-Home mode on the appliance

- ▶ Set to the «Display» or «Operate and display» mode under «V-ZUG-Home» in the user settings.

Connecting the appliance to the home network



- ▶ In the V-ZUG App, add the household appliance.
 - A bluetooth pairing request appears in the V-ZUG App.
 - A 6-digit PIN appears in the display of the household appliance.
- ▶ Enter the 6-digit PIN in the V-ZUG App and confirm the bluetooth pairing request.
 - The name of the active WLAN/Wi-Fi appears in the V-ZUG App and then you are prompted to enter the WLAN/Wi-Fi password.
- ▶ Enter the WLAN/Wi-Fi password.
 - The household appliance is connected to the active WLAN/Wi-Fi connection.



Further information on V-ZUG-Home and its availability can be found at vzug.com.

7 User settings

7.1 Adjusting user settings

- ▶ Long touch the display.
 - The start screen appears.
- ▶ Select  «User settings» and confirm with «OK», if required (see page 15).
- ▶ Select the desired user setting.
 - The main menu for the desired user setting or another submenu with more user settings appears in the display.
- ▶ Make the desired setting.
 - The setting is applied immediately.
- ▶ To exit a submenu, touch .
- ▶ To exit the user settings, touch .



All user settings except for the quiet mode are retained in the event of a power interruption or failure.

7.2 Language

The language in the display can be changed. Different languages are available for selection.

7.3 Childproof lock

The childproof lock is to prevent children accidentally switching on the appliance. When the childproof lock is activated, the appliance can only be operated after first entering a code. The code is displayed in reverse order when unlocking.



The childproof lock is activated within 1 minute of the appliance being switched off.

7.4 Display

Colour scheme

It is possible to choose between a light or dark colour scheme for the display.

Brightness

The brightness of the display can be changed.

Background

The background of the display can be changed. Choose whether to display a solid colour, a texture or a texture featuring various ingredients in the background. When a texture with ingredients is selected, images of different ingredients are displayed on every page in the app view.

7.5 Signals and tones

Quiet mode

The appliance runs as quietly as possible when in quiet mode. All tones are set at the lowest volume. This setting is deactivated when the appliance goes into the EcoStandby mode. The volume of the feedback tones and acoustic signals cannot be changed when in quiet mode.

Sound worlds

The tonality of the acoustic signals and feedback tones can be changed.

Feedback tones

The volume of the feedback tones can be adjusted up or down or turned off completely. Certain feedback tones are not muted for legal and safety reasons.



A short feedback tone is emitted when the appliance is switched off even if the setting is set to «Off» (safety function).

Acoustic signals

The volume of the acoustic signals can be adjusted up or down. They cannot be turned off.



Touch anywhere on the display or open the appliance door to stop an acoustic signal.

7.6 Individual settings

EasyCook – dietary style

Certain foods and food groups can be deactivated so that EasyCook can be adapted to suit a personal dietary style.

EasyCook – cuisines from around the world

Country- and region-specific foods and basic dishes along with their preparation methods can be activated as a package and added to EasyCook.

Start screen

Choose whether the applications should be displayed in the app view or the list view when the start screen is called up.

Subsequent steps

If set to «On», subsequent steps are displayed at the end of operation. If set to «Off», operation is immediately ended.

Temperature unit

The temperature can be displayed in «°C» or «°F».

- °C: Degrees Celsius
- °F: Degrees Fahrenheit

Water hardness

The appliance is equipped with a system that automatically indicates when it is time to descale. The system can be optimized for households with soft water (also through using a water softening appliance) and medium water hardness by changing the user settings to the relevant range of water hardness.

There are 4 setting ranges for water hardness:

Type	Water hardness °fH	Water hardness °dH	Water hardness °eH
Very hard	>38°	>21°	>27°
Hard	27–38°	16–21°	19–27°
Medium	16–26°	9–15°	12–18°

Type	Water hardness °fH	Water hardness °dH	Water hardness °eH
Soft	1–15°	1–8°	1–11°

7.7 Assistance functions

Water compartment flap

If set to «On», the flap of the water tank compartment opens automatically when the water tank is empty and water is required for operation.

Preheat tone

If set to «On», a short preheat tone is emitted when it is time to put the food into the cooking space.

7.8 Date and time

Time synchronization

The «Internet» setting is set automatically when connecting to V-ZUG-Home. The time, date and time zone are then synchronized directly from the app.

Date

The date can be called up and changed.

Automatic summer/winter time adjustment (CEST/ CET)

If this function is activated, the switch between Central European summer and winter time occurs automatically. This requires that the correct date be entered in the user settings.

Time

The time can be called up and changed.

Date and time format

The time can be displayed in the European 24-hour or the US 12-hour format (a.m./p.m.).

The date can be displayed in the DD.MM.YYYY, YYYY-MM-DD or MM/DD/YYYY format.

Time in standby

It is possible to choose between the settings «Off», «On» and «On with night mode».

Clock design

The visual appearance of the clock on the standby screen can be changed. There are three clock faces from which to choose: «Digital», «Analogue» and «Dot».

Night mode

The night mode reduces the brightness of the time display. The start time for the night mode is settable.



The night mode always runs 8 hours.

Time synchronization

It is possible to choose between mains synchronization and real-time clock (RTC).

7.9 V-ZUG-Home

Mode

It is possible to choose between «Off», «Display» and «Operate and display». To connect the appliance to «V-ZUG-Home», «Display» or «Operate and display» must be selected.

Displaying information

Displays all relevant information for the connection.

Restarting interface

The interface can be reset if difficulties are experienced establishing a connection.

Resetting

Disconnects all connections to mobile devices.



Further information on V-ZUG-Home and its availability can be found at vzug.com.

7.10 Appliance information

Identification numbers

The serial number (SN) and article number are displayed.

Version numbers

The current software versions are displayed.

Descaling

The date of the last descaling process, the number of descaling processes already performed and the remaining operating time until the next necessary descaling process are provided (see page 40).

Demo mode

The appliance shows the current demo mode status. The demo mode can only be switched on and off in the service menu.

Contacting Customer Services

The contact information for our Customer Services is displayed.

7.11 Factory settings

Pinned values

Resets all pinned values.

Start screen

Resets the start screen to the app view. Favourites remain unchanged.

Favourites

Entering «OK» clears all existing favourites.

V-ZUG-Home

Disconnects all connections to mobile devices.

Factory settings

Resets the settings to the factory default state. All customized data will be lost.

7.12 EcoManagement

Consumption information

Displays the average energy consumption of the last 25 operations, the total energy consumption for the last month (or since a reset in the last month), the total energy consumption for the last year (or since a reset in the last year) and the total energy consumption.

Consumption indicator

If set to «On», the energy consumed is displayed when the application ends.

Resetting

Resets all EcoManagement counters except for total consumption.

7.13 Customer Services

This part of the menu is intended for service staff and is password-protected.

8 Care and maintenance



Risk of burns from hot surfaces!

Allow the appliance and the accessories to cool down before cleaning.

Incorrect handling can result in damage to the appliance!

Use soft cloths only. Do not use any abrasive, alkaline or highly acidic cleaning agents, metal scrapers that are sharp or scratch, steel wool, scouring pads, etc. as these products will damage the surfaces. Glass surfaces that are scratched can crack.

Never use a steam cleaner to clean the appliance.

8.1 Cleaning the exterior

- ▶ Remove any soiling or residues of cleaning solution immediately.
- ▶ Clean the surfaces and display with a soft cloth dampened with water and a little washing-up liquid.
- ▶ Dry with a soft cloth.

When cleaning the display, the  display lock can be used to protect the operating elements from being unintentionally activated.

8.2 Cleaning the cooking space



The cleaning programme can be carried out with or without the special cleaner.

The special cleaner is available as a special accessory.

- ▶ Any condensate or food particles must be completely removed after each cooking session with steam.
- ▶ Place the stainless steel tray under the perforated cooking tray or wire shelf when cooking to catch food particles and condensate.
- ▶ Remove any soiling from the cooking space while still hand warm. Use a soft cloth dampened with water and a little washing-up liquid. Wipe dry with a soft cloth.
- ▶ Dried-on soiling can be removed more easily with the «Steam cleaning» application.
- ▶ For stubborn soiling, e.g. from chicken, use the cleaning programme «Intensive cleaning» or clean the cooking space when cold with a grease-dissolving spray cleaner or a non-abrasive cream cleaner in accordance with the manufacturer's instructions.



Condensate residue can generally be removed using a mildly acidic cleaning agent or lemon juice.

8.3 Steam cleaning



The appliance must have cooled down before starting.

Remove accessories, cookware or other objects from the cooking space. Do not leave the appliance unattended: the cooking space needs to be wiped during cleaning.



How it functions

The cleaning programme  «Steam cleaning» aids the removal of light soiling in the cooking space. The cleaning effect is achieved through steam.

The cleaning programme guides you step-by-step through the steam cleaning process.



Fill the water tank with fresh water and slot into position in the water tank compartment.

- ▶ Long touch the display.
 - The start screen appears.
- ▶ Select the  «Cleaning» application group and confirm with «OK», if required.
- ▶ Select  «Steam cleaning» and confirm with «OK».
 - The settings for «Steam cleaning» appear in the display.
- ▶ Set a delayed start, if required (see page 17).
- ▶ Press «Start» to start «Steam cleaning».

Removing the accessories and coarse soiling

- ▶ When the corresponding message appears in the display: Remove the accessories.



Remove the shelf guides and place them across the floor of the cooking space during the cleaning process (see page 39).

- ▶ Confirm the message with «OK».
 - The cooking space is cleaned with steam.

Wiping down the cooking space

- ▶ When the corresponding message appears in the display: wipe down the cooking space and open the appliance door as far as its airing position.
- ▶ Confirm the message with «OK».
 - The cooking space is dried.
 - The following appears in the display: «Process finished».

8.4 Cleaning the appliance door

- ▶ Clean the appliance door with a soft cloth dampened with water and a little washing-up liquid.
- ▶ Dry with a soft cloth.

Removing the appliance door



The appliance door is heavy. When removing and reinstalling the appliance door, hold it at the sides firmly with both hands.

- ▶ Open the appliance door as far as it will go.
- ▶ Fold the clips **2** on both door hinges **1** forward.

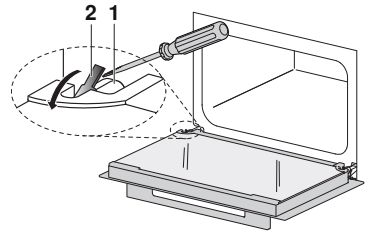

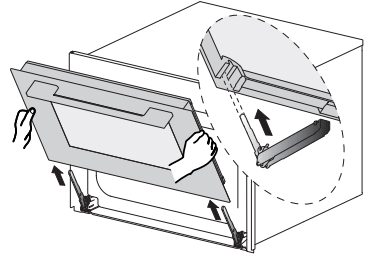

- ▶ Close the appliance door as far as its airing position (about 30°).
- ▶ Lift the appliance door out evenly and at an angle.

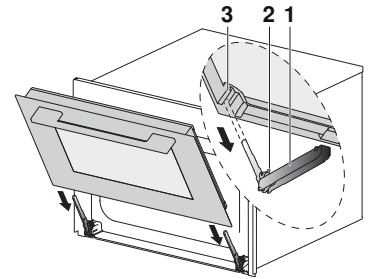

Reinstalling the appliance door

- ▶ Push the appliance door **3** evenly into both hinges **1** as far as it will go.
- ▶ Open the appliance door as far as it will go and fold back the clips **2**.
 - If the appliance door will not close properly, check the clips **2**.
 - Do not force the appliance door closed.



 **Ensure that the appliance door is pushed in as far as it will go otherwise the appliance could get damaged when it is closed.**

Cleaning the door glass

- ▶ Lay the appliance door on a clean, flat surface (covered e.g. with a tea towel) with the handle facing down.
 - Make sure the handle does not come into contact with the surface.
- ▶ Lean against the appliance door.
- ▶ Gently push the outer glass **1** and raise it slightly up and away from the hinges.
- ▶ Remove the intermediate door glass seal **2**.
- ▶ Gently push the middle door glass **3** and raise it slightly up and away from the hinges.
- ▶ Clean the glass panels and dry well.

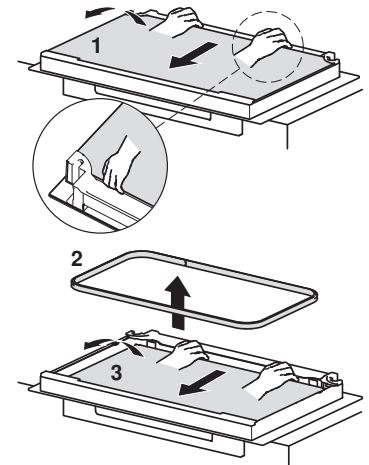

- ▶ Reassemble the glass panels as follows: Insert the middle door glass **3** into the door frame and gently push it back towards the hinges.
 - The markings on the glass must be legible.
- ▶ Reinstall the intermediate door glass seal **2**.

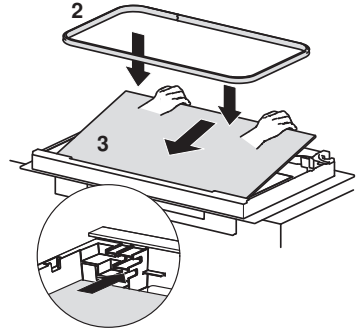

- ▶ Insert the outer door glass **1** into the door frame and gently push it back towards the hinges.
 - The outer door glass **1** can only be put back if positioned correctly with the shiny surface on the outside.

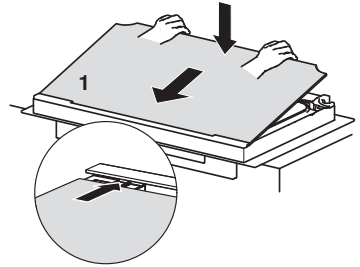

8.5 Cleaning the door seal

- ▶ Clean the door seal with a soft cloth dampened with water, but do not use any cleaning agent.
- ▶ Dry with a soft cloth.

8.6 Replacing the door seal



The door seal cannot be removed. For safety reasons, the door seal must be replaced by our Customer Services.

8.7 Cleaning the accessories and shelf guides

- The stainless steel tray, perforated cooking tray, water tank and shelf guides can be cleaned in the dishwasher.
- Limescale deposits in the water tank can be removed using a standard descaler (do not use washing-up liquid or any abrasive agents).
- ▶ If the water tank valve drips, descale it.

Removing the shelf guides

- ▶ Unscrew the knurled nuts **1** in the front of the shelf guides in an anti-clockwise direction.
- ▶ Pull the shelf guides **2** to the side of the screws and remove from the front.

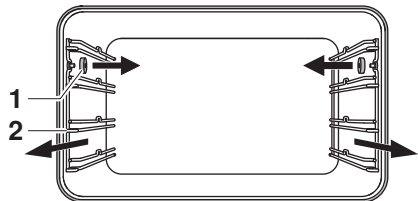

Reassembling the shelf guides

- ▶ Insert the shelf guides into the openings in the back wall of the cooking space and position on the screws. Place the knurled nuts on the screws and tighten securely in a clockwise direction.

8.8 Descaling

How it functions

Whenever steam is produced, depending on the hardness of the local water supply (i.e. the limescale content of the water), limescale is deposited in the boiler. The appliance automatically detects and indicates when descaling is necessary. The cleaning programme guides you step-by-step through the descaling process.

 We recommend descaling the appliance whenever the message appears. Continued failure to descale the appliance will likely impair its functions or cause damage to the appliance. Descaling takes about 45 minutes.

Descaling interval

The time interval between descaling depends on the hardness of the water and frequency of use. If steaming 4x 30 minutes per week, the appliance must be descaled – depending on water hardness – roughly as follows:

Water hardness	Descal after about
Very hard	5 months
Hard	7 months
Medium	9 months
Soft	12 months

Calling up the remaining operating time

The approximate operating time remaining with steam until the next descaling can be called up in the user settings under «Descaling».

Descaler

durgol swiss steamer

 **Using the wrong descaler can damage the appliance!**

Only use «durgol swiss steamer» to descale your appliance. The descaler contains highly effective acid. Immediately rinse away any splashes with water. Follow the manufacturer's instructions.

 See «Accessories and spare parts» for where to obtain this descaler.



«durgol swiss steamer» was developed especially for this appliance. Standard descaling solutions are not suitable as they may contain foam-creating additives or not be effective enough.

Using a different descaler could cause

- overfoaming inside the appliance
- insufficient descaling of the boiler
- damage to the appliance in the worst case.

Starting descaling



The appliance must have cooled down before descaling.

Remove accessories, cookware or other objects from the cooking space. Do not leave the appliance unattended: during the descaling process, the descaler must be added and the water tank must be emptied. The appliance door must be closed during descaling.

When the message «Do you want to descale the appliance now? You must accompany the process.» appears in the display:

- ▶ Touch «Yes».
 - The following appears in the display: «The appliance is being prepared for descaling.»



If an acoustic signal is emitted and «Residual heat too high» appears in the display, the appliance has not cooled down sufficiently and the descaling process cannot be started.

- ▶ Allow the appliance to cool down.
- ▶ When the corresponding message appears in the display: pour 0.5 l undiluted descaler into the water tank, insert the tank and confirm with «OK».
 - The descaling process starts.
 - The following appears in the display: «Descaling appliance.»



For safety reasons, once started the descaling process cannot be cancelled.

Discarding the rinsing solution

- ▶ When the corresponding message appears in the display: remove the water tank, pour the rinsing solution away and fill it with 1 l warm water.
- ▶ Put the water tank back.
 - The rinsing phase starts automatically.
 - The following appears in the display: «Rinsing appliance.»
- ▶ Repeat the procedure as often as required by the appliance.



As the water is heated up during final rinsing, the appliance door may steam up.

Ending the descaling process

- ▶ As soon as the corresponding message appears: remove, empty and dry the water tank.
- ▶ Confirm the message with «OK».
 - The following appears in the display: «Appliance was descaled successfully.»
- ▶ Confirm the message with «OK».
 - The appliance is ready for operation again.
- ▶ Wipe up any water in the bottom of the cooking space with a soft cloth.



After descaling, if the  application is used the water that is pumped back into the water tank at the end of cooking may be cloudy. This will not affect the cooking or baking characteristics nor the quality of the food being cooked or baked.

9 Trouble-shooting

You may be able to trouble-shoot the following malfunctions yourself. If not, note down the error message in full (message, F and E numbers) and call Customer Services.

9.1 Error messages

Message	Possible cause	Solution
▪ «FX/EXX»	▪ Various situations can lead to an error message.	<ul style="list-style-type: none"> ▶ Acknowledge the error message by touching «OK». ▶ Switch the power supply off for about 1 minute. ▶ Switch the power supply back on. ▶ If the error appears again, note down the error message in full along with the serial number (SN) of the appliance (see page 45). ▶ Disconnect from the power supply. ▶ Contact Customer Services.
▪ «UX/EXX»	▪ Disruption in the power supply.	<ul style="list-style-type: none"> ▶ Acknowledge the error message by touching «OK». ▶ Switch the power supply off for about 1 minute. ▶ Switch the power supply back on. ▶ If the error appears again, note down the error message in full along with the serial number (SN) of the appliance (see page 45). ▶ Disconnect from the power supply. ▶ Contact Customer Services.
▪ «Residual heat – Do not remove the water tank.»	▪ The temperature of the water in the boiler is too high.	<ul style="list-style-type: none"> ▶ Wait for it to cool down (this can take up to 30 minutes). <p>For safety reasons, the water is not pumped off until it has dropped below a certain temperature.</p> <p>The appliance can still be used.</p>
▪ «Descaling failed – Appliance was not descaled.»	<ul style="list-style-type: none"> ▪ Used unsuitable descaler. ▪ Descaling was not carried out correctly. 	<ul style="list-style-type: none"> ▶ Descalate again using the recommended descaler. ▶ If the message does not disappear after repeating the descaling process several times, note down the error message in full along with the serial number (SN) of the appliance (see page 45). ▶ Contact Customer Services.

Message	Possible cause	Solution
<ul style="list-style-type: none"> «Please fill with water – but the water tank is still full.» 	<ul style="list-style-type: none"> Boiler filling error 	<ul style="list-style-type: none"> Remove the water tank and then slot straight back into position. If the error appears again, note down the error message in full along with the serial number (SN) of the appliance (see page 45). Contact Customer Services.

9.2 Other possible problems

Problem	Possible cause	Solution
<ul style="list-style-type: none"> Appliance is not working 	<ul style="list-style-type: none"> A household fuse or circuit breaker has tripped. 	<ul style="list-style-type: none"> Change the fuse. Reset the circuit breaker.
	<ul style="list-style-type: none"> The fuse or circuit breaker keeps blowing. 	<ul style="list-style-type: none"> Contact Customer Services.
	<ul style="list-style-type: none"> Interruption in the power supply. 	<ul style="list-style-type: none"> Check the power supply.
	<ul style="list-style-type: none"> Demo mode is switched on. 	<p>The demo mode can only be switched off with the security code.</p> <ul style="list-style-type: none"> Contact Customer Services.
	<ul style="list-style-type: none"> Appliance is faulty. 	<ul style="list-style-type: none"> Contact Customer Services.
<ul style="list-style-type: none"> Cooking time seems longer than usual 	<ul style="list-style-type: none"> Appliance only has a one-phase connection. 	<ul style="list-style-type: none"> Connect appliance with a two-phase connection.
<ul style="list-style-type: none"> Steam is not visible during steam cycle 	<ul style="list-style-type: none"> The temperature of the cooking space is over 100 °C. 	<p>No solution required: steam over 100° C is not visible.</p>
<ul style="list-style-type: none"> Water in door-mounted condensate trough 	<ul style="list-style-type: none"> When using applications with steam, steam condenses on the appliance door and the water that results collects in the door-mounted condensate trough once the appliance door is opened. 	<p>The door-mounted condensate trough is used to collect condensed steam; residual water collecting here is normal.</p> <ul style="list-style-type: none"> Wipe up any residual water in the door-mounted condensate trough.
		<p>Any residual water in the door-mounted condensate trough 1 will collect in the condensate trough 2 when the appliance door is closed. Wipe out the door-mounted condensate trough to prevent residual water from collecting in the condensate trough.</p>

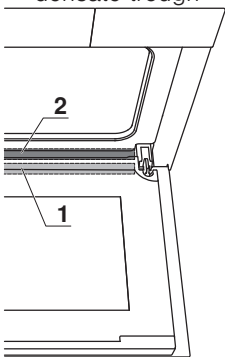

Problem	Possible cause	Solution
<ul style="list-style-type: none"> Control panel steams up 	<ul style="list-style-type: none"> Steam escaping during applications with steam. 	<p>Briefly steaming up is normal.</p> <ul style="list-style-type: none"> ▶ When closing the appliance door make sure that it forms a seal all the way round. ▶ If it continues to steam up heavily, contact Customer Services.
<ul style="list-style-type: none"> The appliance makes noises during operation 	<ul style="list-style-type: none"> Appliance can make noises at any time during operation (switching, pumping and fan noises). 	<p>Such noise is normal.</p>
<ul style="list-style-type: none"> Clock is not running correctly 	<ul style="list-style-type: none"> Irregular mains frequency. 	<ul style="list-style-type: none"> ▶ Turn off the mains synchronization. <p>Or:</p> <ul style="list-style-type: none"> ▶ Connect the appliance to the internet. ▶ The time is automatically synchronized.
	<ul style="list-style-type: none"> Internal pulse generator is imprecise when mains synchronization is turned off. 	<ul style="list-style-type: none"> ▶ Contact Customer Services.

9.3 After a power failure



The user settings remain unchanged.

Brief power failure during operation

- The current operation of the appliance is cancelled.
- The following appears in the display when the appliance is switched on: «Process was cancelled due to a power failure».
- ▶ Press «OK» to confirm the message.
 - The start screen appears.

Brief power failure during descaling

- The descaling process is interrupted.
- The following appears in the display when the appliance is switched on: «Power failure. Descaling is resumed.»
- ▶ Press «OK» to confirm the message.
 - The descaling process resumes.

Prolonged power failure

The appliance goes through its initial set-up process after a prolonged power failure. However, only the time and date need to be reset in order to operate the appliance again. It is not necessary to make any other settings.

- If a descaling process was running, the descaling process continues.

10 Accessories and spare parts

The accessories shown below as well as spare parts can be ordered in addition to the scope of delivery of the appliance. Ordering spare parts is subject to charge, except in the event of warranty claims. Please give the product family of the appliance and exact designation of the accessory or spare part when ordering parts.

10.1 Accessories

Stainless steel tray

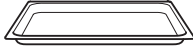

Perforated cooking tray



Wire shelf



10.2 Special accessories

Information at: www.vzug.com

10.3 Spare parts

Shelf guides, left/right

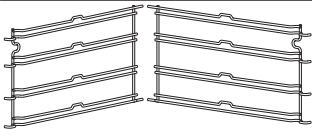

Knurled nut



durgol swiss steamer descaler



Lid for water tank

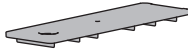

Water tank

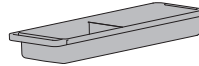

The descaler is also available from specialist retailers.

11 Technical data

External dimensions

- ▶ See installation instructions

Electrical connection

- ▶ See identification plate 1

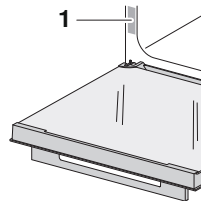

11.1 Note for testing institutes

Placing thermocouples between the appliance door and the seal can cause lack of leak-tightness and thus measuring errors.

The usable volume within the meaning of EN 50304 / EN 60350 is obtained with the shelf guides disassembled.

General note

Maximum load capacity: 3 kg

11.2 Temperature measurement

The temperature inside the cooking space is measured when the cooking space is empty according to an internationally accepted standard. Own measurements can be imprecise and are not suitable for checking the accuracy of the temperature.

11.3 Product fiche

In accordance with EU Regulation No.: 65/2014

Brand	–	V-ZUG
Type of appliance	–	Built-in steamer
Model designation	–	S4T
Energy efficiency class	-	-
Energy consumption of conventional mode ¹⁾	kWh/cycle	–
Energy consumption of hot air / forced convection mode ²⁾	kWh/cycle	–
Energy Efficiency Index per cavity ³⁾	-	-
Number of cavities	-	1
Measurement and calculation methods used	–	EN 60350-1

1) Required to heat a standardized load per cavity

2) Required to heat a standardized load per cavity

3) Measurement methods: see EU Regulation No. 66/2014, Annex II, Chpt. 1

11.4 Product information

In accordance with EU Regulation No.: 66/2014

Model designation	–	S4T
Mass of appliance	kg	34
Heat source per cavity	–	Electricity
Volume per cavity	l	48

11.5 EcoStandby

To prevent unnecessary energy consumption, the appliance is equipped with the automatic energy-saving «EcoStandby» function.

In accordance with EU Regulation No. 2023/826

Off mode	W	–
Power consumption in standby mode	W	0.20
Standby mode with information or status display	W	0.80
Networked standby mode	W	1.50
Time required for the appliance to automatically reach the applicable low-power mode.	Mins	4

12 Tips and tricks

12.1 General tips

- A variety of food can be cooked at the same time, e.g. rice or pulses together with vegetables that have similar cooking times, saving energy.
- Cook grains (e.g. rice and millet) and pulses (e.g. lentils), adding an appropriate amount of liquid, directly in suitable tableware.
- Put the tableware directly on the perforated cooking tray or wire shelf.

13 Disposal

13.1 Packaging



Never allow children to play with packaging material due to the danger of injury or suffocation. Store the packaging material in a safe location or dispose of it in an environmentally-friendly way.

13.2 Safety

Render the appliance unusable to prevent accidents caused by improper use (e.g. through children playing):

- ▶ Disconnect the appliance from the mains. With a fixed appliance, this is to be carried out by a qualified electrician. Then cut the mains cable off flush with the appliance.

13.3 Disposal



-  The «crossed out wheeled bin» symbol requires the separate collection of waste electrical and electronic equipment (WEEE). Such equipment can contain hazardous, environmentally harmful materials.
- These appliances are to be handed over to a designated collection point for the recycling of electrical and electronic equipment and must not be disposed of with unsorted household waste. And in this way, you will be helping to protect resources and the environment.
- For more information, please contact the local authorities.

Index

A	
Accessories	12, 45
App	
Moving	14
App view	10
Appliance	
Disposal	47
Switching off	25
Switching on	13
Appliance description	9
Appliance door	
Reinstalling	38
Removing	37
Appliance information	
Contacting Customer Services	35
Demo mode	35
Descaling	35
Identification numbers	35
Version numbers	35
Appliance tips	26
Calling up	26
Application	15
Changing	16
Selecting	15
Starting	16
Application group	
Selecting	15
Application tips	19
Hiding	19
Showing	19
Applications	26
Assistance functions	34
Preheat tone	34
Water compartment flap	34
B	
Boiler filling error	43
C	
Cancelling an application	23
Care and maintenance	36
CircleSlider	
Reaction	16
Using	14
Cleaning	
Accessories	39
Appliance door	37
Cooking space	36
Door glass	38
Door seal	39
Shelf guides	39
Cleaning the exterior	36
Clock	23
Hiding	23
Hiding during operation	17
Showing	23
Showing during operation	17
Clock design	34
Construction	9
Cooking space	
Temperature measurement	46
Cuisines from around the world	30
D	
Date and time	
Automatic summer/winter time adjustment (CEST/ CET)	34
Clock	34
Clock synchronization	34
Date	34
Date and time format	34
Night mode	34
Time in standby	34
Time synchronization	34
Delayed start	17
Setting	17
Descaling	40
durgol swiss steamer	40
Ending	41
Failed	42
How it functions	40
Interval	40
Rinsing phase	41
Starting	41
Dietary styles	30
Display	
Background	32
Brightness	32
Colour scheme	32
Operating	13
Display lock	22
Turning off	22
Turning on	22
Disposal	47
Door seal	
Replacing	39
E	
EasyCook	29
Food groups	29
EcoManagement	
Consumption indicator	36
Consumption information	36
Resetting	36
EcoStandby	46

Electrical connection	45
End	17
End of operation	24
Ending an application before time	23
External dimensions	45

F

F and E messages	42
Factory settings	35
Favourites	35
Pinned values	35
Start screen	35
V-ZUG-Home	35
Favourites	19
Changing	20
Creating	19
Deleting	20
Starting	20
Function bar	10
Function buttons	10
Expanding	14

G

General tips	47
--------------------	----

H

Hot massage stones	29
Hot wraps	28
Hygiene	29
Hygiene baby bottles	29
Hygiene preserving jars	29

I

Identification plate	45, 51
Individual settings	
EasyCook – cuisines from around the world	33
EasyCook – dietary style	33
Start screen	33
Subsequent steps	33
Temperature unit	33
Water hardness	33

K

Keep warm	28
-----------------	----

L

Levels	11
List view	10
Load capacity	45
Long cooking time	43

M

Malfunctions	42
Model designation	2

O

Operating and display elements	10
Operating time	16
Setting	16
Operation	13
Options	18
Selecting	18
Starting	18
Other possible problems	43

P

Perforated cooking tray	12
Pinning	20
Main value	21
Resetting a main value	21
Power failure	44
Power interruption	44
Preserve jam	29
Problems	42
Product fiche	46
Product information	46

Q

Queries	51
Quick information	
Displaying	13
Quick instructions	52
Quiet mode	22
Turning off	22
Turning on	22

R

Ready to start	11
Refilling water tank	14
Refreshing towels	28
Regeneration	27

S

Safety precautions	
Appliance-specific	5
Before using for the first time	6
Burns hazard	7
Correct use	6
General	5
How to avoid damaging the appliance	8
Instructions for use	6
Note on use	7
Risk of injury	7
Risk to life	8
Seed cushions	29
Service & Support	51
Service agreement	51
Setting options	11
Setting range	17

Settings	
Changing.....	18
Checking.....	18
Shelf guides	
Reassembling.....	40
Removing.....	39
Signals and tones	
Acoustic signals.....	33
Feedback tones.....	33
Quiet mode.....	32
Sound worlds.....	33
Spare parts.....	45
Special accessories.....	13, 45
Stainless steel tray.....	12
Start later.....	19
Setting.....	19
Starting.....	19
Start screen.....	13
Steam cleaning.....	37
Steaming.....	26
Subsequent steps.....	24
Cancelling operation.....	25
Continuing operation.....	25
Symbols.....	5

T

Technical data.....	45
Temperature sensor.....	11
Testing institutes.....	45
Timer.....	21
Changing.....	21
Checking.....	21
Setting.....	21
Starting.....	21
Switching off before time.....	22
Tips and tricks.....	47
Type.....	2

U

U and E messages.....	42
User settings.....	32
Adjusting.....	32
Appliance information.....	35
Childproof lock.....	32
Customer Services.....	36
Date and time.....	34
Display.....	32
EcoManagement.....	36
Factory settings.....	35
Individual settings.....	33
Language.....	32
Signals and tones.....	32
V-ZUG-Home.....	35
Using for the first time.....	9

V

Vacuisine.....	27
Selecting and starting.....	28
Validity.....	2
Values	
Adjusting.....	15
Saving.....	16
V-ZUG App.....	31
V-ZUG-Home.....	31
Displaying information.....	35
Mode.....	35
Resetting.....	35
Restarting interface.....	35

W

Water tank.....	13
Emptying.....	26
Filling.....	14
Wellness.....	28
Wire shelf.....	12
WLAN connection.....	31

14 Service & Support



The «Trouble-shooting» section gives you valuable tips on how to deal with minor malfunctions yourself, saving you the time and trouble of calling out a service technician and any cost that goes along with it.

Information on the V-ZUG warranty can be found at www.vzug.com →Service →Warranty information. Please read this information carefully.

Please register your V-ZUG appliance straightaway:

- online at www.vzug.com →Service →Online warranty registration or
- using the enclosed registration card.

This will allow you to take advantage of the best possible support in the event of a fault in the appliance during the guarantee period. You will require the serial number (SN) and appliance designation to register your appliance. You will find them on the identification plate of your appliance.

My appliance information:

SN: _____ **Appliance:** _____

Please have this appliance information to hand when contacting V-ZUG. Thank you.

Identification plate

- ▶ Open the appliance door.
 - The identification plate is located on the left-side panel.

Your repair order

Call the free service number 0800 850 850 to contact your nearest V-ZUG service centre. You can arrange an on-site visit by us by phone if you wish.

General queries, accessories and service agreement

V-ZUG will be happy to help you with any general administrative or technical queries, to accept your orders for accessories and spare parts and to inform you about our progressive service agreements. You can contact us by calling tel. +41 58 767 67 67 or by going to our website at www.vzug.com.

Quick instructions

On/Off

Touch the display to switch the appliance on. Long press and hold the  function button to switch the appliance off.



Quick information

Move app



Operation

The appliance is operated using the display. Place your finger on the CircleSlider and move it in a circle.

Adjustable value

Favourite

Temperature

The temperature can be set using the CircleSlider.

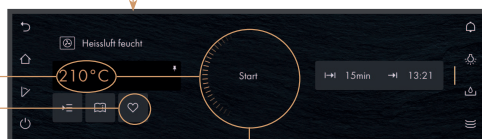

1063302-10

